

MGS

Micronizzatore

Dati tecnici

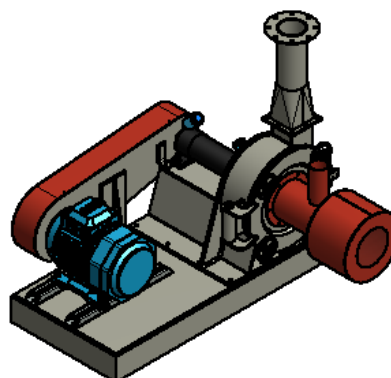
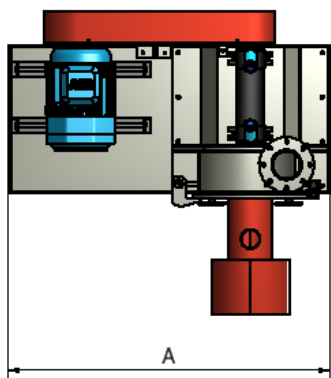
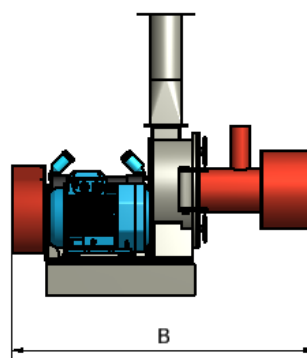
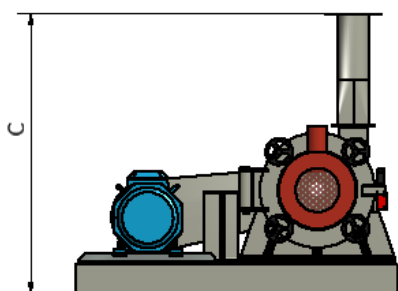

Micronizzatore			MGS 30	MGS 40
Dimensioni	a	mm	1070	1450
Dimensioni	b	mm	1120	1370
Dimensioni	c	mm	1250	1405
Peso totale mulino	kg		550	800
Potenze elettriche installate				
Macinazione	kW		11	18.5 ÷ 22

I dati forniti sono puramente indicativi. GTS si riserva di modificare pesi, misure e potenze